



IdeaPro

**NOWA SÓL
POLAND**



SHOT - BLASTING MACHINES

TECHNOLOGY • PRODUCT • QUALITY

SHOT - BLASTING MACHINES

Abrasive blasting is a process which involves blasting with an abrasive jet the surface to be processed. This treatment is suitable for items made of ferrous and non-ferrous metals, and their alloys, plastic, rubber, glass, ceramics, stone and concrete. All shot-blasting machines manufactured by IdeaPro are equipped with dust removal systems conforming to environmental requirements. The control systems are operated via PLC controllers and provided with a screen for the visual monitoring of the process parameters.

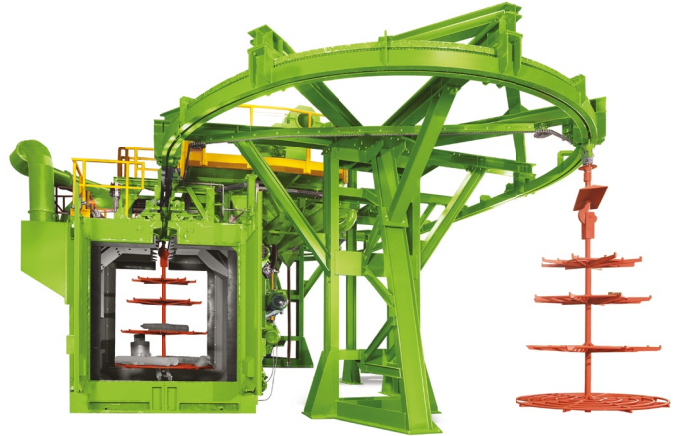

The applications of abrasive blasting:

- removing all kinds of solid contaminants from the processed surface
- achieving the required surface texture
- preparing the surface before applying the protective and decorative coating
- surface roughening and matting
- edge trimming and rounding
- removing mould flashes
- preparing galvanised surfaces for painting
- enhancing fatigue strength by shot peening



OWKS Chambers Shot - Blasting Machines with Rotary Table

OWKS shot-blasting machines are designed for cleaning medium-and large-sized cast-iron and cast-steel castings, as well as large-sized steel structures. The items to be processed are placed on a rotary table which is fitted with a travel drive and a rotational drive. The essential operating units are blasting wheels.

For cleaning narrow spaces and other hard-to-reach areas, the machine can be equipped with a pneumatic deep-cleaning unit. The accurate positioning of the blasting wheels and the rotational motion of the table guarantee precise and uniform surface cleaning.

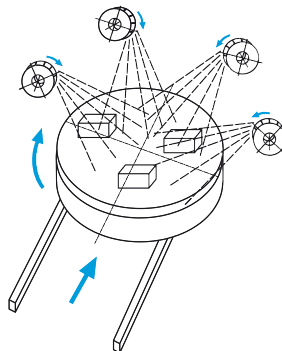

Shot - blasting machine		OWKS 3,5x2,0	OWKS 3,5x3,5
Diameter of working table	mm	3500	3500
Max. height of load	mm	2000	3500
Max. weight of cleaned load	kN	100-250	100-250

OWZ Overhead Rail Shot - Blasting Machines

OWZ shot-blasting machines are designed for cleaning medium- and large-sized items. The pieces to be processed are suspended from the appropriate hangers (either individually or in groups according to their dimensions and individual weight). The hangers are then transferred one by one into the blastroom, where the shot-blasting process takes place. The hangers can be either rotated mechanically or advanced linearly during the cleaning process. Hangers with long and flat items can not be rotated. OWZ machines are equipped with a closed-circuit suspended conveyor. The accurate positioning of the blasting wheels and the rotational movement of hangers, where possible, guarantee precise and uniform surface cleaning.

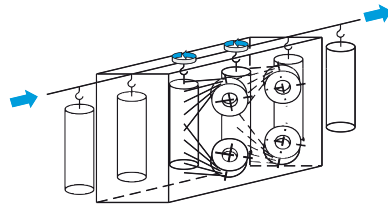

Shot - blasting machine		OWZ 0,3x1,0	OWZ 0,5x1,5	OWZ 0,5x2,0	OWZ 1,0x1,5	OWZ 1,2x2,0	OWZ 2,0x2,5
Max. diameter or width of load	mm	300	500	500	1000	1200	2000
Max. height of load	mm	1000	1500	2000	1500	2000	2500
Max. load capacity of hanger	kN	1	1-20 /to discuss with the Customer/				

OWH Spinner - Hanger Shot - Blasting Machines

OWH shot-blasting machines are designed for cleaning small-, medium- and large-sized items. The pieces to be processed are suspended from the appropriate hangers (either individually or in groups according to their dimensions and individual weight). The hangers are then transferred one by one into the blastroom, where the shot-blasting process takes place. Once in the chamber, the hanger rotates around its axis and moves back and forth. The constant rotation of the item in the shot-blasting area, combined with the periodic reversals of the rotation direction and the changing position of the hanger, guarantees precise and uniform surface cleaning. The device can be outfitted with Y- or I-shaped travel tracks.

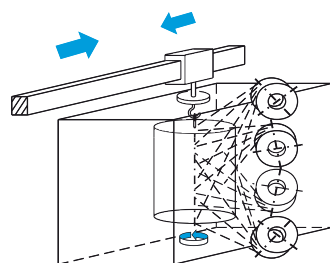

Shot - blasting machine		OWH 0,8x1,0	OWH 1,0x1,5	OWH 1,5x2,0	OWH 2,0x2,5	OWH 2,5x4,0	OWH 3,5x4,5	OWH 3,5x6,0
Max. diameter of load	mm	800	1000	1500	2000	2500	3500	3500
Max. height of load	mm	1000	1500	2000	2500	4000	4500	6000
Max. load capacity of hanger	kN	5,0	5,0	20	20	80	80	150

OWB Roller Conveyor Shot - Blasting Machines

OWB shot-blasting machines are designed for cleaning metal sheets, profiles, sections, pipes and flat welded structures. The items are placed horizontally on a roller conveyor, which transports them by continuous motion through the blastroom where the shot-blasting process takes place. The transport speed is continuously adjustable according to the level of the surface contamination and the degree of cleaning required. OWB machines are provided with a system for the post-cleaning removal of the shot-blasting medium from the top surface. The accurate positioning of the blasting wheels helps to ensure the thorough and uniform cleaning of all surfaces during a single pass through the shot-blasting machine.

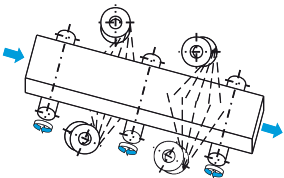

Shot - blasting machine		OWB 500	OWB 1000	OWB 1500	OWB 2000	OWB 2500	OWB 3000
Max. width of load	mm	500	1000	1500	2000	2500	3000
Max. height of load	mm	400	500	600	600	600	600
Max. load 1 meter of conveyor	kN/m	10		20			
Max. length of load	m	6			12		

OWR Shot - Blasting Machines For Pipes and Round Rod

OWR shot-blasting machines are designed for cleaning the external surfaces of pipes and round bars before coating (e.g. varnish or plastic), applying thermal insulation, etc. During the cleaning process, the pipes are moved back and forth. The speed can be adjusted according to the pipe diameter, the type and degree of contamination, and other requirements related to the process efficiency and final surface quality. The accurate positioning of the blasting wheels and the back-and-forth motion of the item being processed guarantee precise and uniform surface cleaning.

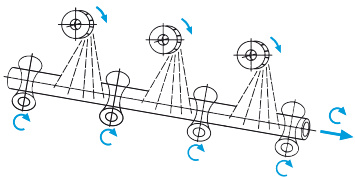

Shot - blasting machine		OWR 500	OWR 1000	OWR 1500
Max. width of load	mm	500	1000	1500
Max. load 1 meter of conveyor	kN/m	5		
Max. length of load	m	12		



OWPS Wire Mesh Conveyor Shot - Blasting Machines

OWPS shot-blasting machines are designed for cleaning small- and medium-sized items.

The mesh conveyor transports items by continuous motion through the blastroom, where the shot-blasting process takes place.

The conveyor speed is continuously adjustable according to the degree of surface contamination and the desired final surface quality. The accurate positioning of the blasting wheels helps to ensure the thorough and uniform cleaning of all surfaces during a single pass through the shot-blasting machine.

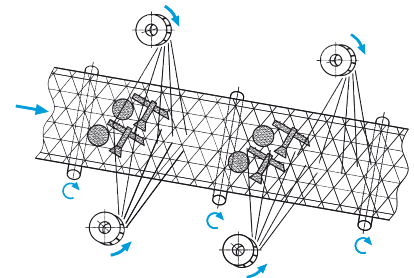

Shot - blasting machine		OWPS 500	OWPS 1000	OWPS 1500
Max. width of load	mm	500	1000	1500
Max. height of load	mm	400	500	600
Max. load 1 meter of conveyor	kN/m	5		



OWS Rotary Table Shot - Blasting Machines

OWS shot-blasting machines are designed for processing medium- to large-sized items. The pieces to be processed are placed on a rotary work table, which is fixed to the blastroom door. Once the door is closed, the table, together with the items, is transported into the blastroom, where the shot-blasting process takes place. The accurate positioning of the blasting wheels and the rotation of the table guarantee precise and uniform surface cleaning.

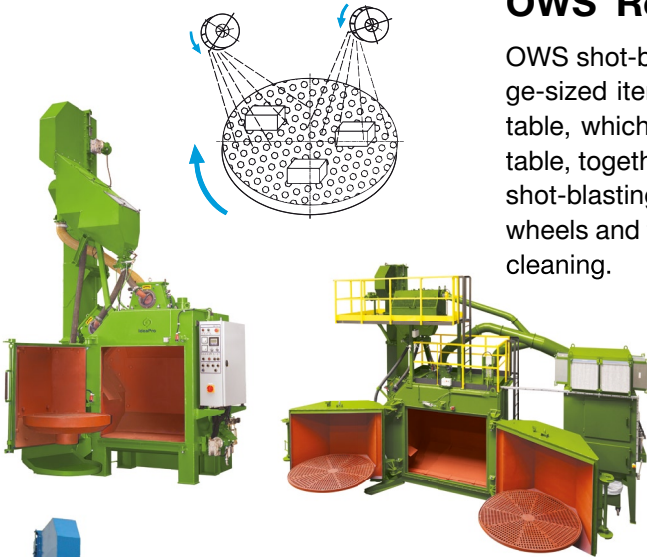

Shot - blasting machine		OWS 1000	OWS 1500	OWS 2000
Diameter of working table	mm	1000	1500	2000
Max. height of load	mm	700	800	800
Max. table of load	kN	5	10	20
Number of working tables		1 or 2	1 or 2	1 or 2

OWT Rubber Belt Shot - Blasting Machines

OWT shot-blasting machines are designed for processing small-sized items. The pieces to be processed are positioned manually or by using a loading device in a trough formed by a perforated belt. The motion of the belt causes the intense movement of the items during the shot-blasting process. The pieces are unloaded automatically into a container or into a receiving conveyor by the reverse movement of the belt. The accurate positioning of the blasting wheels and the rotation of the belt guarantee precise and uniform surface cleaning.



Shot - blasting machine		OWT 200	OWT 400
Max. weight of single load	kg	200	400
Loading volume	m ³	0,1	0,3
Max. weight of one detail	kg	15	15
Min. dimension 1 pc detail (axbxh)	mm	25x25x25	25x25x25

OWG Steel Belt Shot - Blasting Machines

OWG shot-blasting machines are designed for processing small- to medium-sized items, including in particular cleaning cast-iron and cast-steel castings. The machine is suitable for cleaning high-temperature castings. The pieces to be processed are positioned using a loading device in a trough formed by a steel belt. The motion of the belt causes the intense movement of the pieces during the shot-blasting process. The items are unloaded automatically into a container or into a receiving conveyor by the reverse movement of the belt. The accurate positioning of the blasting wheels and the rotation of the belt guarantee precise and uniform surface cleaning.



Shot - blasting machine		OWG 800	OWG 1500
Loading volume	m ³	0,8	1,5
Max. weight of single load	kg	2000	3000
Max. weight of one detail	kg	50	50
Min. dimension 1 pc detail (axbxh)	mm	50x50x50	50x50x50

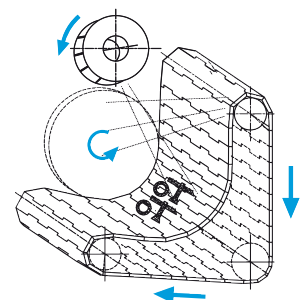

SPECIAL SHOT - BLASTING MACHINES

IdeaPro manufactures special shot-blasting machines designed for the abrasive blasting of items of atypical geometry. These machines are custom-made to the requirements of individual clients.

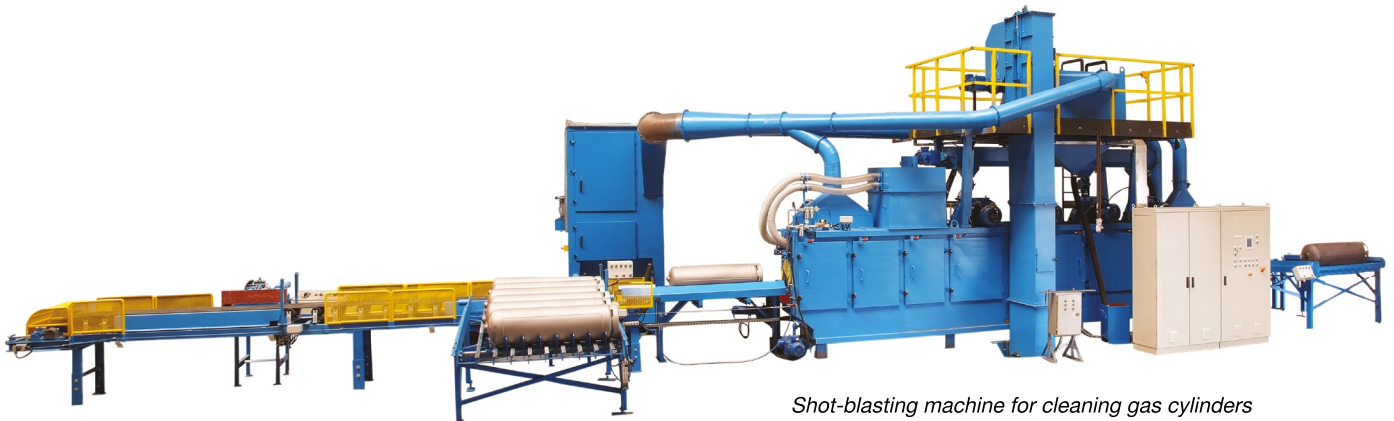

Shot-blasting machine for cleaning gas cylinders

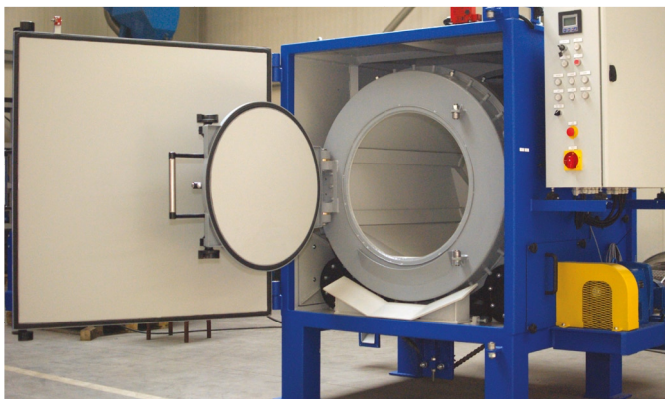

Shot-blasting machine for cleaning surgical instruments



Shot-blasting machine for cleaning rolled steel wire

SHOT - PEENING MACHINES Machines for plastic surface treatment

Shot peening is a plastic surface treatment procedure which enhances the fatigue strength of components in items exposed to fatigue stress. During the shot-peening process, ball-shaped shots are ejected via a blasting wheel at 40÷80 m/s towards the processed surface, causing permanent plastic deformation of the surface of the item processed. The compressive pre-stress caused by shot peening reduces the peak tensile stress during subsequent operation, thus increasing the service life of elements processed by shot peening. This method has replaced other, far more expensive technological solutions.

Shot peening can be used for processing: large-sized gear wheels, axles and shafts, turbine blades, springs: disk, coil, flat, valve and clutch springs, crankshafts and connecting-rods, stabilisers.

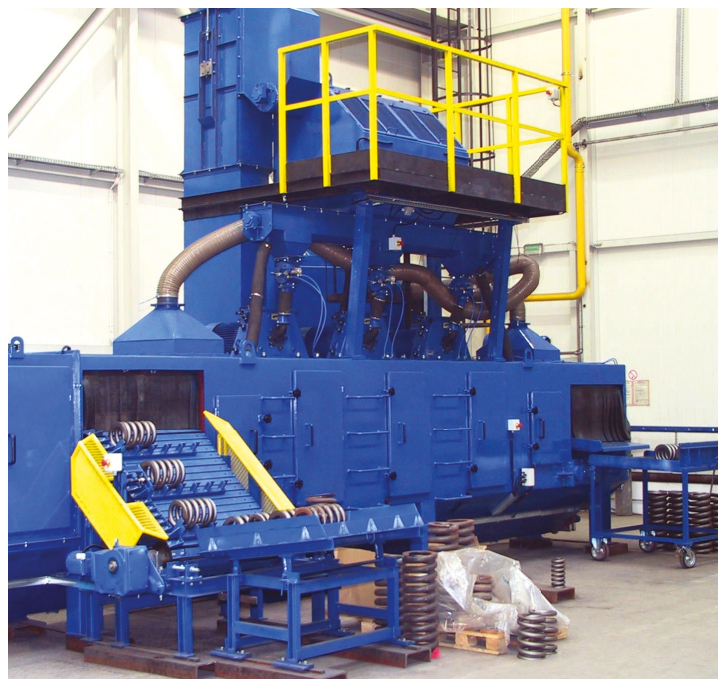

WR BLASTING WHEELS

WR blasting wheels are the essential operating components of airless shot-blasting machines. They supply the appropriate kinetic energy to the shot-blasting medium. Blasting wheels are supplied complete, including electric motors. The shot-blasting machines currently manufactured by **IdeaPro** feature blasting wheels equipped with WR120, WR180 and WR380 direct drives. Impact turbines manufactured by **IdeaPro** can additionally be mounted in the shot-blasting machines of other manufacturers.

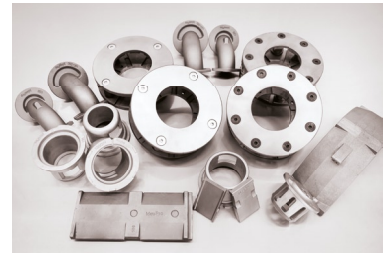
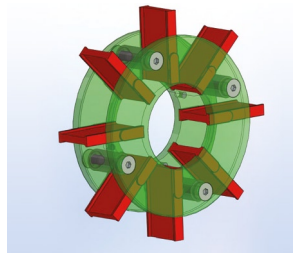
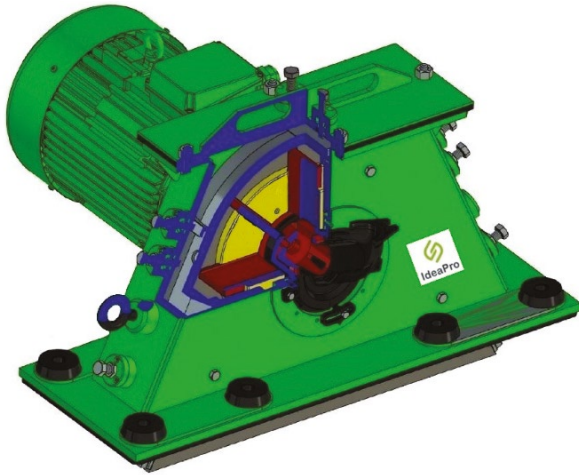

TURBINES TYPE WR		WR 120	WR 180	WR 380
Shot capacity	kg/min	120	180	380
Shot granulation	mm	0,2-2,0	0,2-2,0	0,2-2,0
Motor power	kW	7,5	11,0	22,0
Max. rotor speed (adjustable down)	rpm	2930	2930	2930
Max. speed of shot ejection	m/s	80	80	80

OPK AIR BLASTING CHAMBERS

OPK air-blasting machines are designed for use in individual or small-scale production for processing medium- and large-sized items. The items to be processed are placed on the table of a travelling car. The essential operating unit is a pneumatic device. The cleaning process can be controlled manually by the operator or via a PLC-controlled manipulator.

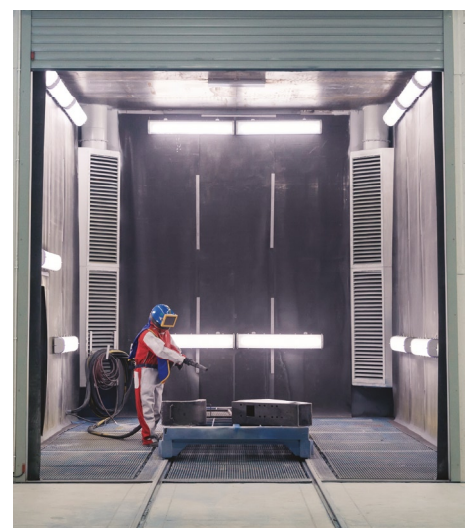

The machines, devices, and complete production lines manufactured by IdeaPro are designed specifically for use e.g. in the foundry, automotive, glass, iron and steel, mining, ceramics, insulating and refractory materials industries, and many other



We provide assistance and technical support services, putting our consultants and their extensive experience at your disposal

We provide comprehensive project implementation services, which include:

- the development of underlying concepts
- the formulation of technical and business objectives
- industry-specific projects, e.g. water supply and compressed air lines, gas and electric systems
- foundations and construction works
- machinery and equipment
- shop floors and steel structures
- dust removal systems
- power supply and electric control systems
- the organisation of project-related supplies and deliveries
- the installation and start-up of the resulting technological lines
- the implementation of manufacturing processes

Drawing on our many years of experience, we have developed our own know-how based on technologies designed for building machines and technical equipment, including in particular:

- shot-blasting machines
- sand processing stations
- turbine mixers
- vibro-fluidised bed and blade-mixer coolers
- fluidised bed and vibro-fluidised bed dryers
- pulse-press moulding machines
- automatic moulding lines
- the maintenance and online monitoring of manufactured and operating equipment and production lines

We also provide supply services in the following areas: designing, engineering, control and automation, repairs, mechanical treatment, welding steel structures, shot blasting, and painting, as well as other services, according to our own machinery park



IdeaPro

PPP IdeaPro Sp. z o.o.
Dolnośląska 8
67-100 Nowa Sól POLAND
tel. +48 68 444 89 42
www.ideapro.com.pl
marketing@ideapro.com.pl



012

SHOT-BLASTING MACHINES. Edition 2018